



# PresSure Products Company, Inc.

## PresSure Products N29TP Ultrasonic Stencil Cleaning System



In the beginning, PresSure Products Company's PPC-N29 Ultrasonic Stencil Cleaning System was revolutionary. Now we've made it even better.

The new PPC-N29TP provides an innovative, cost-effective, and environmentally sound solution to your cleaning requirements—from frameless and pump-print plastic stencils to QTS Quick Frame models. The system also effectively cleans misprinted boards and other items using fixturing available from PPC.

Stencils are inserted into the PPC-N29TP and cleaned in an upright position with perpendicular ultrasound. The result? A perfectly cleaned stencil—and all in a matter of minutes.

The PPC-N29TP's inline filtration system continuously removes soil loading and keeps the cleaning medium at a high level of quality for up to a year or longer, depending on production. The system is designed to run with aqueous solutions (no flash-point, low VOC content) in a 100% closed-loop process, making it possible to separate residues. This ensures a cleaning process that meets your facility's economic and environmental demands now and in the future.

While incorporating all the features of our original design, the new PPC-N29TP also offers numerous enhancements including:

- High-efficiency ultrasonic generators and transducers
- Simplified, reliable solid state design
- Early-warning filter change alarms
- User-friendly color touchpad operator interface
- Built-in diagnostic and status indicators

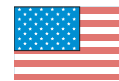

**MADE IN THE USA**

**PresSure Products Company, Inc.** has been an American manufacturing leader since 1959. For over four decades, thousands of customers worldwide have come to rely on the safety, quality, and reliability that have become PresSure Products' trademark.

For more information on the PresSure Products N29TP Ultrasonic Stencil Cleaning System, call us toll-free at (800) 624-9043. PresSure Products Company's engineering staff is available for consultation, product demonstration, and price quotations 8:00 a.m. to 4:30 p.m. EST Monday through Friday.

# PresSure Products N29TP Ultrasonic System

## An Unmatched Standard of Cleaning Efficiency

The PPC-N29TP gives you peak cleaning effectiveness in all areas of operation:

- Cleans SMT-adhesive or solder paste stencils and circuit boards
- Unique filtration system means no contamination buildup (solder paste, adhesives, fluxes, and other soils)
- Complete set of custom handling tools for non-standard stencils, misprinted boards, and more also available upon request
- Integrated drying chamber dries one stencil while the next one is being cleaned, ensuring short process cycle times and high throughput rates

## Versatile, Easy to Use—and Economical

- Low cleaning process costs
- Evaporation cleaning agent losses minimized by double-cover design
- Cleans stencil dimensions up to 29" x 29"
- No complex connections: Only a single 230 VAC connector is necessary
- Durable stainless-steel construction
- Small foot print (34" wide, 40" high, 21" deep)
- Minimal maintenance required
- Standard-size filter cartridges allow for easy, low-cost maintenance
- Manufactured in the USA
- Portable—Heavy-duty casters allow the N29 to be easily moved
- Cleaning chemicals are permanently recycled—nothing to drain

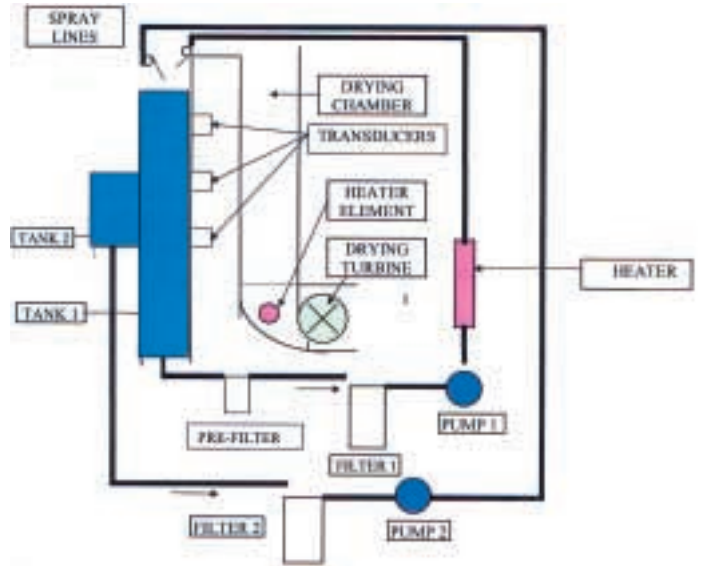

## PresSure Products Ultrasonic System Detail:

- Footprint:** 34" x 21"
- Height:** 40"
- Weight (dry):** 435 lbs. (197 kg.)
- Recommended Cleaner:** Zestron® Vignon® SC200
- Fluid Capacity:** 14.5 gal. (55 L)
- Filtration:** Dual 20", 5 µm cartridge filters; one single gravity filter
- Power Source:** 230 VAC / 60 Hz / 10amps



## Also from PPC...

*The PresSure Products PPC-N29 cleaning system push-button model, shown at left, is also available. Call 1-800-624-9043 for details.*